

A stylized world map in shades of grey, overlaid with a network of interconnected nodes and lines, suggesting global connectivity. The map is centered on the Atlantic Ocean. The text 'Internationalisation Unit' is prominently displayed in a bold, teal font on the right side of the map. A large, thin teal circle is partially visible on the right edge of the image.

Internationalisation Unit



The Malta Council for
Science & Technology



Aims and Objectives

- The main aim of the internationalisation unit is to **strengthen international R&I collaboration amongst local and foreign researchers and stakeholders**
- The Unit implements regional and international funding programmes, **using national funds**, aimed at the local R&I stakeholder community

Internationalisation Programmes



MCST TÜBİTAK 2023
JOINT CALL FOR R&I PROPOSALS

Bilateral Programmes:

- SINO-MALTA Fund
- MCST-TÜBİTAK



Multilateral Programmes:

- PRIMA
- BlueBio ERA-NET COFUND



Horizon Europe Partnerships:

- Clean Energy Transition Partnership (CETP)
- Sustainable Blue Economy Partnership (SBEP)
- Transforming Health and Care Systems Partnership (THCS)





TRANSFORMING HEALTH
AND CARE SYSTEMS

Partnership in Transforming Health and Care Systems – THCS

General Overview

<https://www.thcspartnership.eu/>

Funded by the European Union under the Horizon Europe Framework Programme - Grant Agreement Nº: 101095654. Views and opinions expressed are however those of the author(s) only and do not necessarily reflect those of the European Union or European Health and Digital Executive Agency (HADEA). Neither the European Union nor the granting authority can be held responsible for them.



Co-funded by the
European Union

THCS: a Co-Funded Partnership



- New generation of EU Partnerships **brings together the European Commission and public and/or private partners** to address Europe's most pressing challenges
- Commitments by national partners for financial and in-kind contributions and co-funded up to 30% by the European Union



Why a Co-Funded Horizon Europe Partnership?

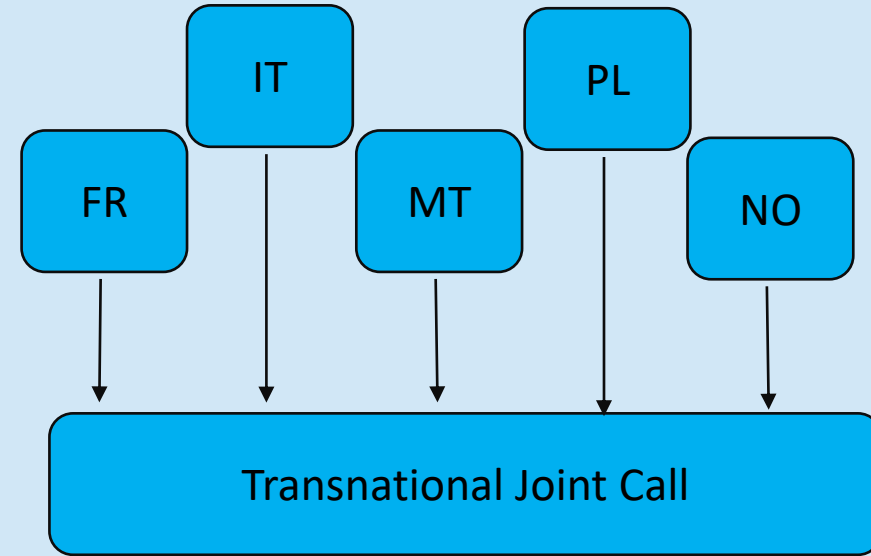
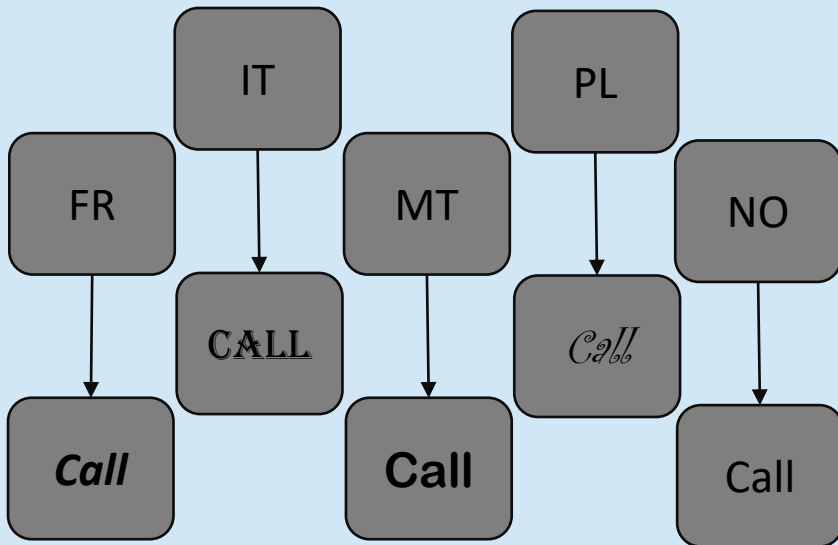

- **Better use of R&I resources and solve common challenges more effectively.**
- Each partner (funding organisation) funds research carried out in their own country for selected proposals.

Quick Facts and Figures

**6 co-funded
calls for R&I
proposals**

**63 partners
from 26
countries &
European
Commission**

**€ 305 M
planned
investments
over 7 years**



Co-funded by the
European Union

THCS Vision and Objectives

Health and Care systems:

- high quality
- fairly accessible
- sustainable
- efficient
- resilient
- inclusive



- Increase funding opportunities and strengthen the R&I community.
- Fill the knowledge gap.
- Increase the ability to implement innovation.
- Intensify cooperation among countries and beyond healthcare.
- Increase stakeholders' involvement.

SRIA - <https://www.thcspartnership.eu/thcs/strategie-overview/strategic-research-and-innovation-agenda.kl>



Co-funded by the
European Union

Funded by the European Union under the Horizon Europe Framework Programme - Grant Agreement N°: 101095654. Views and opinions expressed are however those of the author(s) only and do not necessarily reflect those of the European Union or European Health and Digital Executive Agency (HADEA). Neither the European Union nor the granting authority can be held responsible for them.



TRANSFORMING HEALTH
AND CARE SYSTEMS

“Innovate to Prevent: Personalised Prevention in Health and Care Services”

Joint Call 2024 General Considerations

<https://www.thcspartnership.eu/funding/pre-announcement-of-the-second-joint-transnational-call.kl>

Funded by the European Union under the Horizon Europe Framework Programme - Grant Agreement N°: 101095654. Views and opinions expressed are however those of the author(s) only and do not necessarily reflect those of the European Union or European Health and Digital Executive Agency (HADEA). Neither the European Union nor the granting authority can be held responsible for them.



Co-funded by the
European Union

Participating Countries

17 Member States:

*Italy, Austria, Belgium, Denmark, Estonia, France, Ireland, Latvia, Lithuania, **Malta**, Poland, Portugal, Romania, Slovenia, Spain, Sweden, The Netherlands*

3 Associated Countries: *Iceland, Israel, Norway*

2 Non-EU Countries: *Switzerland, Scotland*



Co-funded by the
European Union

Funded by the European Union under the Horizon Europe Framework Programme - Grant Agreement N°: 101095654. Views and opinions expressed are however those of the author(s) only and do not necessarily reflect those of the European Union or European Health and Digital Executive Agency (HADEA). Neither the European Union nor the granting authority can be held responsible for them.

“Innovate to Prevent: Personalised Prevention in Health and Care Services”

- **Support the implementation of innovative person-centred health and care models addressing prevention strategies, with the key help of existing IT and digital technologies and services**
- Max. funds that can jointly be requested by Malta-based eligible partner/s per project: **€ 500,000**
- Projects up to **36 months**



Call Now Open! - [Announcement Of The Second Joint Transnational Call \(thcspartnership.eu\)](https://thcspartnership.eu)



Project Consortium

- ✓ 3 partners from at least 3 different participating countries.
- ✓ Max. 9 partners per project consortium
- ✓ Max. 3 partners per country
- ✓ Max. 2 self-funded (collaborators) partners
- ✓ The project coordinator must be eligible for funding by a regional/national funding organisation participating in the call.
- ✓ Abide to the respective national rules by the national funding authority (**CHECK CALL TEXT 2024!**)
- ✓ A proposal can be rejected if one of the partners is not eligible



Forming a Consortium

One partner must assume the role of Coordinator:

- Ensure eligibility of own entity and of partner entities within the consortium according to national/ regional regulations
- Submits Intent to Apply and Full Proposal on behalf of consortium on the online submission tool by the established deadlines
- The same applicant may only be project Coordinator of **ONE** project proposal



All Consortium Partners must have a Participant Identification Code (PIC Code)



Intent to Apply

- ✓ **Deadline: 16th April 2024**
- ✓ Brief **document** to provide the Call Secretariat of the topic, brief description and the partners within the proposal
- ✓ Proposals without an Intent to Apply will not be eligible and will not be evaluated

Full Proposal

- ✓ **Deadline: 14th May 2024**
- ✓ Project duration: 12-36 months
- ✓ Proposals are to be complete, written in English, submitted to the online platform tool and respect page limits



Evaluation Criteria

The evaluation process is administered by the THCS Call Secretariat and will remain anonymous both for the national funding agencies and applicants

- ✓ **Excellence** – relevance and the need for your project
- ✓ **Impact** – show how project output makes a difference and to whom
- ✓ **Implementation** – show how the execution of the project is managed



Proposals recommended for funding will also be reviewed for **ethical clearance** for alignment with ethical norms and regulations

Provisional Timeline





Joint Call 2024

National Considerations

<http://mcst.gov.mt/funding-opportunities/>

Funded by the European Union under the Horizon Europe Framework Programme - Grant Agreement N°: 101095654. Views and opinions expressed are however those of the author(s) only and do not necessarily reflect those of the European Union or European Health and Digital Executive Agency (HADEA). Neither the European Union nor the granting authority can be held responsible for them.



Co-funded by the
European Union

Eligible for National Funding

Eligible Entities must be registered in Malta or must have an operating base in Malta

**Limited Liability
Company**

Partnerships

**Non-profit making
Organisations**

**Voluntary
Organisations**

Professional Bodies

Cooperatives

Public entities

**Research &
Knowledge-
Dissemination
Organisations**

Funding Modalities

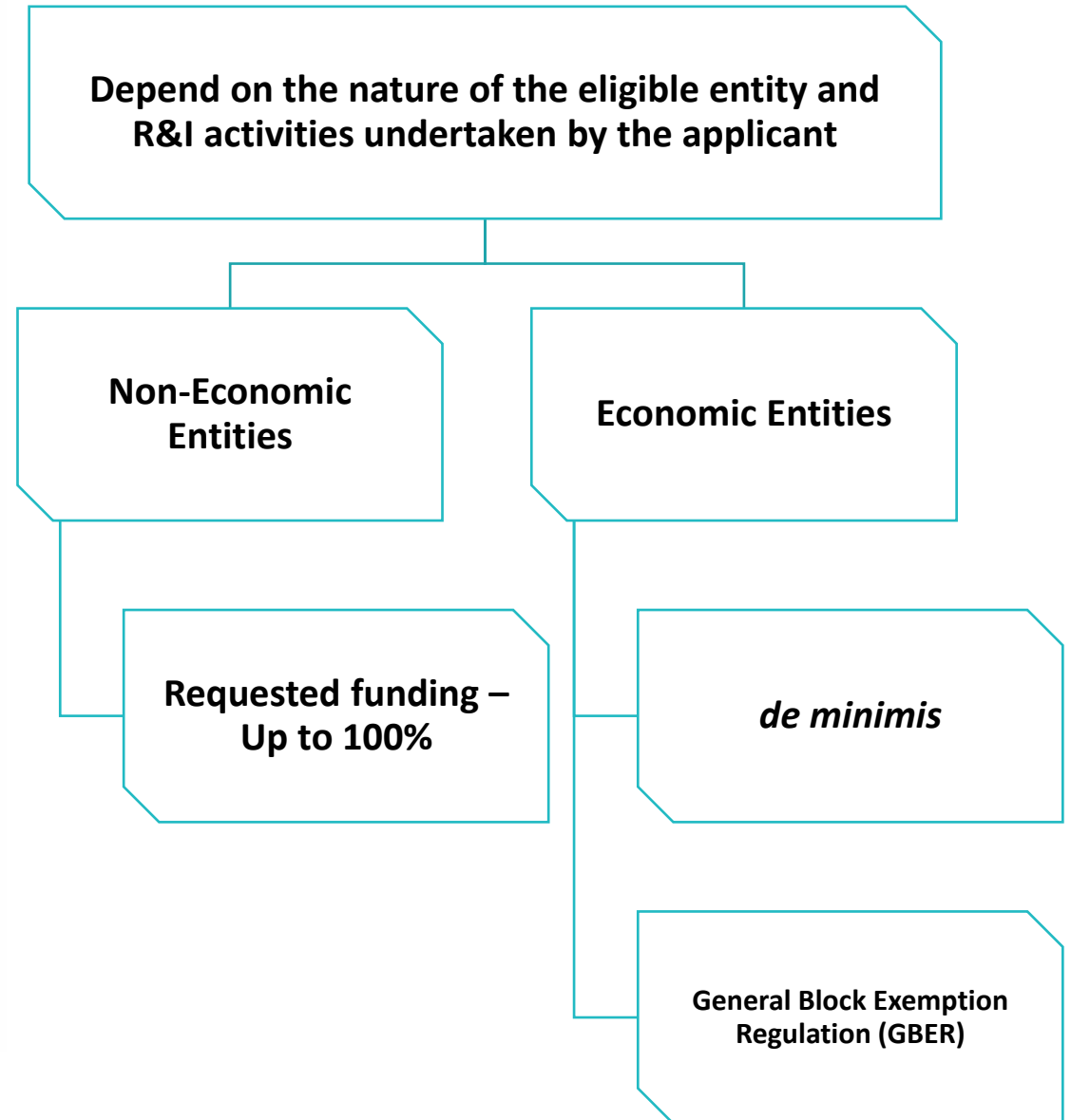
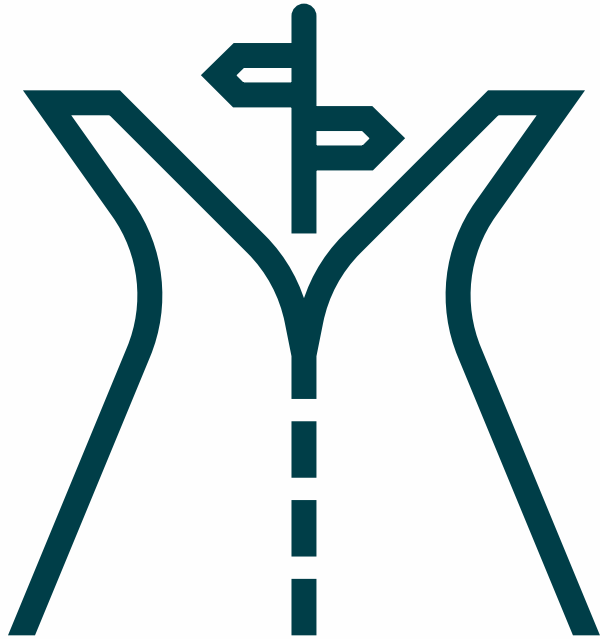

Aid Intensity

Economic entity	de minimis*	GBER
Requested funding	Up to 75%	Up to 70%
Own contribution	Remainder % (not in-kind)	Remainder % (not in-kind)

***de minimis capping of €300k over a span of 3 consecutive years**

Aid Intensity	Undertaking Size		Extra funding for projects prioritizing Effective Collaboration & Wide Dissemination
25%	Small	+ 20%	+ 25%
	Medium	+ 10%	
	Large	+ 0%	

Eligible Costs

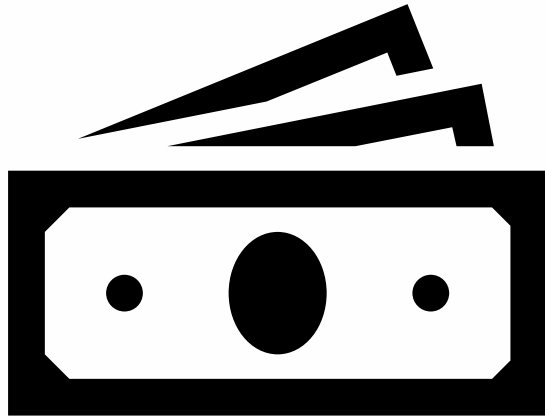

Personnel

**Specialised
Equipment &
Consumables**

Subcontracting

**Costs of IP and
Knowledge
Transfer activities**

**Travel &
Subsistence***

**Overheads and
Other Operating
Expenses**

***Some restrictions apply under GBER**

Personnel Costs

Non-economic/*de minimis*/GBER

- Project Management – up to 10% of the project value
- Students – EUR 6,000-8,000 p.a.
- Maximum of 1720 hours p.a.
- Hourly rates specified in national rules.

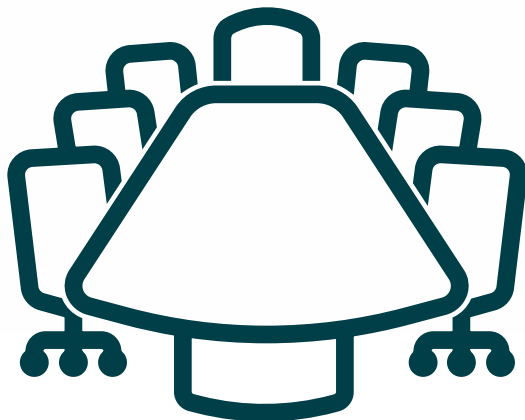

€z = (basic salary + allowances) / yearly workable hours of the employee.

Role in Project	Hourly rates in 2025	Hourly rates in 2026	Hourly rates in 2027	Limits per project
Management or equivalent	Up to €57.89/hour	Up to €60.78/hour	Up to €63.82/hour	Max 2 per project
Senior Researcher ³ or equivalent	Up to €40.80/hour	Up to €42.84/hour	Up to €44.98/hour	Max 2 per project
Researcher ⁴ or equivalent	Up to €29.23/hour	Up to €30.69/hour	Up to €32.22/hour	No limits

³ The term 'senior researcher' is to be used for a postdoctoral researcher with a specialist and high level of local and international experience in the field. Individuals possessing a high level of experience in industry can still be considered.

⁴ The term 'researcher' is to be used for a Bachelor's, Master's or a Ph.D. degree holder and hence the hourly rate should be equivalent to the degree held by the relevant individual.

Instruments, Specialised Equipment and Consumables

Non-economic /de minimis

- Cost to purchase/lease specialised equipment
- Cost of research consumables should not exceed 30% of the project value

GBER

- **Depreciation costs** of specialised equipment for the extent and period used for the project. To be verified by a certified public accountant.
- The costs and/or leasing of specialised equipment, are eligible only to the extent and for the period used for the project. The depreciation costs corresponding to the life of the project are eligible.
- Cost of research consumables should not exceed 30% of the project value

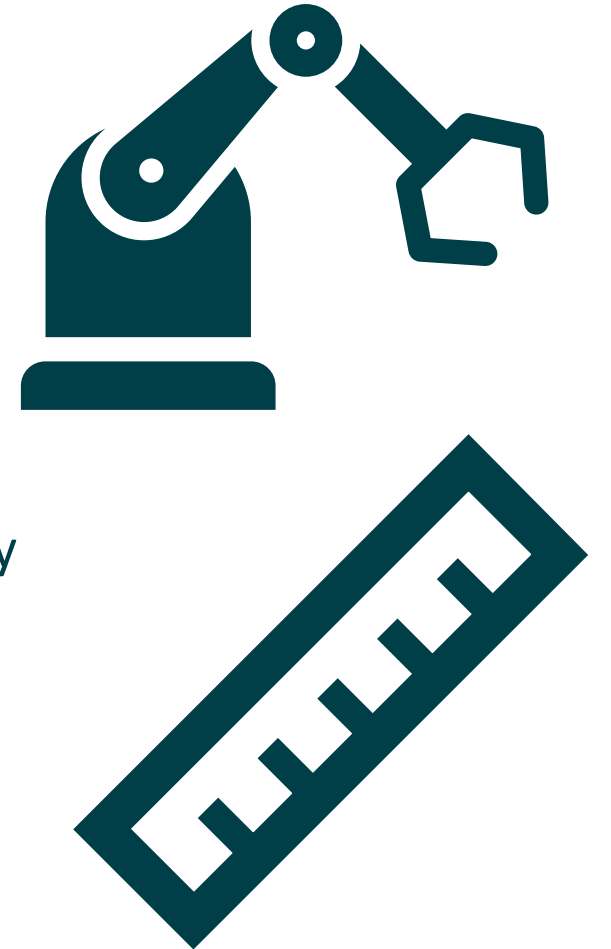

Travel and Subsistence

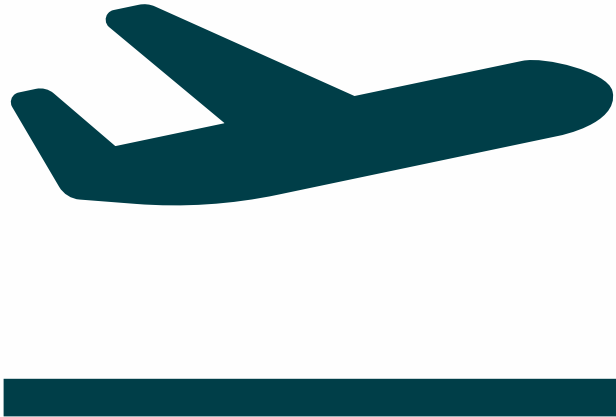

Non-economic/*de minimis*

- Economy flights, and public transport (most economic solutions) and per diems for up to 14 days in a row.
- For the attendance of consortium meetings, up to two persons will be eligible to attend the meeting.
- For the attendance of international conferences, up to two persons will be eligible to attend per six months.

GBER

- Travel costs are not eligible

Subcontracted Activities

Non-economic/*de minimis*/GBER

- Allowed up to 25% of the project value
- Must follow fair procurement procedures
- *To be discussed with the Call Manager at application stage*

IP and Knowledge Transfer Activities

Non-economic/*de minimis*/GBER

- Costs of knowledge transfer activities and patents bought or licensed from outside sources at arm's length conditions.
- *To be discussed with the Call Manager at the application stage*

Overheads and Other Operating Expenses

Non-economic/*de minimis*/GBER

- Are costs that are incurred directly as a result of the project.
- These will be covered at 20% of direct eligible costs claimed.
- *To be discussed with the Call Manager at the application stage*

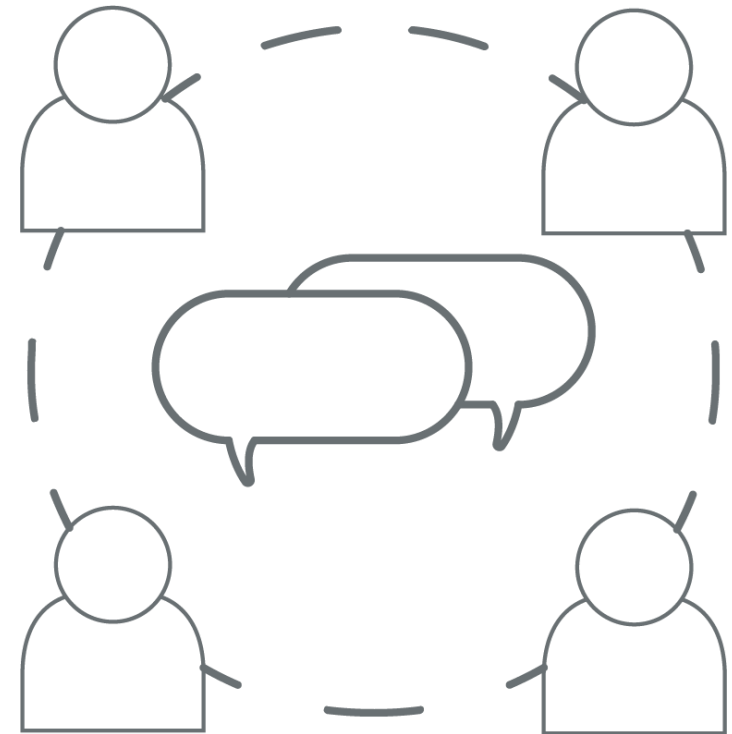

Ineligible Costs

1. Expenses related to loans, interest etc.
2. Expenses which are recoverable through other funding mechanisms
3. Re-purchase of the same equipment originally procured through other funding mechanisms
4. Purchase and/or leasing of equipment and services from partners or their subsidiaries
5. Standard office equipment
6. Personnel hours for travelling
7. Any other costs that are not listed as eligible costs in the National Rules.



For further info check the MCST National Rules at:
<https://mcst.gov.mt/funding-opportunities/>

Submission Process

THCS Partnership

Intent to Apply
letter submission
by Project
Coordinator – **16th**
April 2024 (14:00
CET)

Full proposal
submission by
Project Coordinator
– **14th May 2024**
(14:00 CET)

THCS Secretariat
[online submission tool](#)
General contact: thcs@zonmw.nl

MCST

National Application
Form and Annexes by
each Malta-based
applicant –
14th May 2024 (23:59
CET)



MCST
eusubmissions.mcst@gov.mt

Submission Documents - Annexes

Attachments	Public entities	Public RKDOs	<i>de minimis</i>	GBER
<i>de minimis</i> Form			X	
Enterprise Size Declaration Form & Undertaking in Difficulty				X
Declarations for Augmented Aid Intensity				X
Audited financial statements (last 3 years)*			X	X
Public entities (not RKDOs)	X			
Public RKDOs		X		
Detailed Budget Breakdown Form	X	X	X	X

- Each Malta-based partner in a local consortium must submit Annexes.
- **To be submitted by Principal Investigator or directly by partners within a local consortium.**

**start-ups that do not have the above documents available, please provide financial projections for three (3) years signed by an auditor*



Important Links

THCS Website:

<https://www.thcspartnership.eu/>

**Call Text, Guidance, Online
Platform:**

<https://www.thcspartnership.eu/funding/pre-announcement-of-the-second-joint-transnational-call.kl>

**MCST National Rules, Application
Form & Annexes**

<https://mcst.gov.mt/funding-opportunities/>

Social Media:

@THCS_HEU on LinkedIn and Twitter

@MCST on Facebook and LinkedIn



Partner Search

PART FINDER New announcement ♡ 🔊 👤 Your account

🔍 Type minimum 3 letters Advanced filters ↑ Sort ↓

Type of collaboration: Choose an option
Announcing country:
Status: Choose an option
Classification areas:
Partner type: Choose an option
Countries searched:
Keywords:
From the date of publication: rrrr-mm-dd

Programme / Call name: Not specified
Not specified
THCS Partnership
EIG CONCERT-Japan 10th joint call
INNOGLOBO programme
M-ERA.NET 3
ERA4Health Partnership

Looking for: Partner Partner name: Leszek Partner type: Other Status: Published	Coin ATM machine The manufacturer of self-service machines for the exchange of coins for banknotes is looking for an international partner to whom... 🕒 Published on 2023-02-28	Announcing country: United Arab Emirates Countries searched: United Arab Emirates Observations: 0
Looking for: Partner Partner name: R&D Organisation, SME's, Labs Partner type: Other Status: Published	Looking for new... Generally, we are focused on genetic and molecular diagnostics, but our experience includes also telemedicine, med-tech, and... 🕒 Published on 2023-02-28	Announcing country: Poland Countries searched: Belgium, France, Spain, Netherlands, Germany, Norway, Turkiye, United Kingdom, Italy Observations: 0 Details
Looking for: Project Partner name: ASM - Market Research and Analysis Centre Partner type: Enterprise Status: Published	Neuromarketing research, co-design, socio-economic analysis 🕒 Published on 2023-02-21	Announcing country: Poland Countries searched: Austria, Belgium, Denmark, Finland, France, Greece, Spain, Netherlands, Germany, Portugal, Sweden, Italy Observations: 0 Details
Looking for: Partner Partner name: AD Partner type: Other Status: Published	- LOOKING FOR INNOVATIONS? SHOW ME YOUR COMPANY (website) I'm innovator and bussines analyst around wide market with experience as project manager/owner,executive with...	Announcing country: Poland Countries searched: Australia, Austria, Belgium, Brazil, Bulgaria, Czechia, Denmark, Egypt, Estonia, Finland, France, Gambia, Greece, Netherlands, Ireland, Iceland, Japan, Yemen, Canada, Kazakhstan, South Korea, Lithuania, Latvia, Malaysia, Germany, Norway, Oman, Poland, South Africa, Portugal, Romania, Slovenia, United States of America, Sudan, South Sudan, Switzerland, Taiwan - Province of China, Turkiye, Turkmenistan, Hungary, United Kingdom, Italy, United Arab Emirates



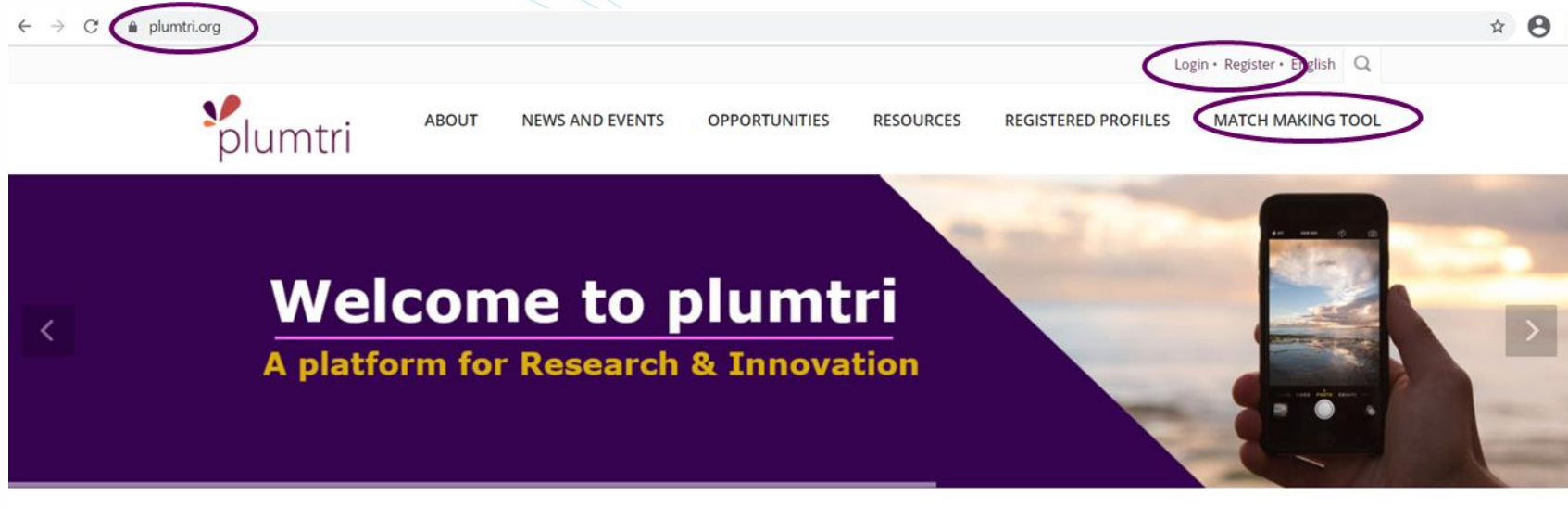

One-stop shop for National and Mediterranean researchers, to keep abreast with:

- ✓ Latest News and Events
- ✓ Funding and Work Opportunities in R&I
- ✓ Facilitate networking amongst Mediterranean R&I community
- ✓ Partner Search Facility
- ✓ **Matchmaking Tool**



THANK YOU FOR YOUR ATTENTION

- Organise Information Sessions
- Organise One-to-One sessions for tailor-made advice
- Facilitate search for partners - plumtri
- Networking opportunities – brokerage events

Contact us on:

annalisa.cartabia@gov.mt

christy.baldacchino.2@gov.mt

eusubmissions.mcst@gov.mt